



上海交通大学
SHANGHAI JIAO TONG UNIVERSITY



2012.11



上海交通大学
SHANGHAI JIAO TONG UNIVERSITY





上海交通大学
SHANGHAI JIAO TONG UNIVERSITY





20

- ◆ 1988
- ◆ 1996
- ◆ 1999
- ◆ 2000
- ◆ 2000
- ◆ 2004
- ◆ 2008
- ◆ 2010
- ◆





0157

DDT





300





上海交通大學
SHANGHAI JIAO TONG UNIVERSITY







EFSA

“ ” 2012.11.2



上海交通大學
SHANGHAI JIAO TONG UNIVERSITY



<

<

<

<

<





上海交通大学
SHANGHAI JIAO TONG UNIVERSITY





1996

100

191

47

103

21

32

31

56





$\frac{3}{4}$

$\frac{3}{4}$

10





ACS ACO PG







Bt





上海交通大学
SHANGHAI JIAO TONG UNIVERSITY





上海交通大学
SHANGHAI JIAO TONG UNIVERSITY





EDCs





上海交通大学
SHANGHAI JIAO TONG UNIVERSITY





Our Stolen Future

<

<

<





EDCs

<

<

<

<

,

<





上海交通大學
SHANGHAI JIAO TONG UNIVERSITY



-





EDCs

<

40

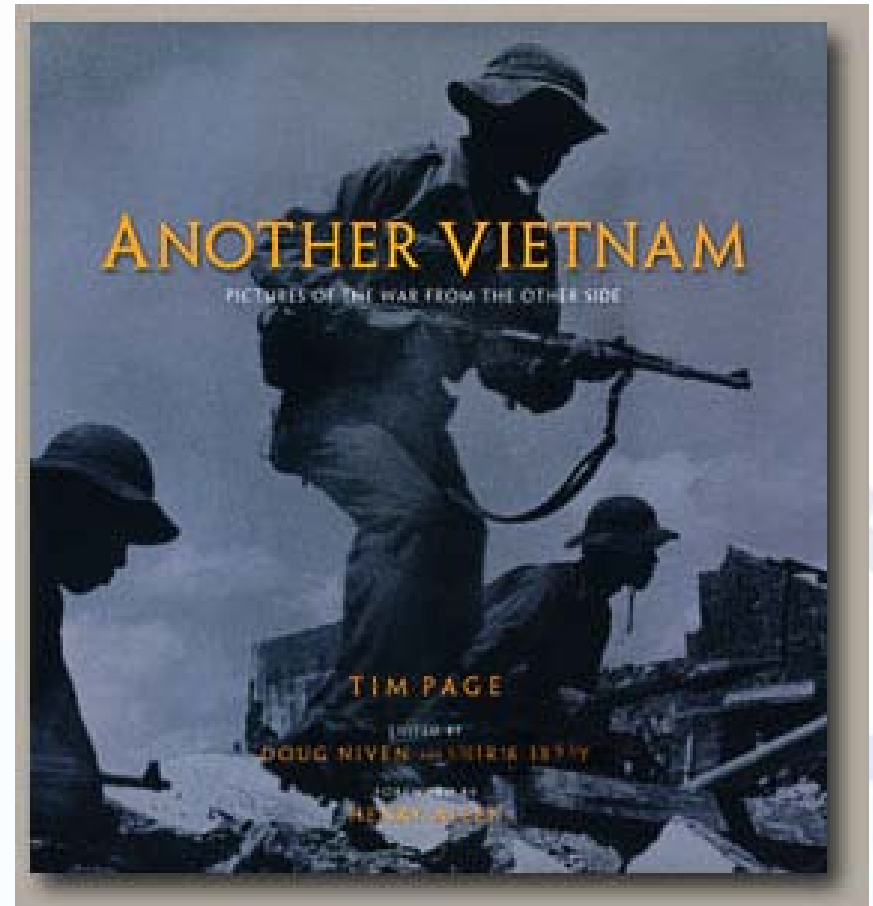



“ ”

80

14

10





上海交通大學
SHANGHAI JIAO TONG UNIVERSITY





<

T





A

A BPA ,

A

A

EPA

50 / /

0.6 /





//

//



,

DEHP

30





2

,

(DES)

DES

,

,

,

"

"

,





3

,

4



,



上海交通大学
SHANGHAI JIAO TONG UNIVERSITY





上海交通大学
SHANGHAI JIAO TONG UNIVERSITY



<

<

<

<

<

<





上海交通大學
SHANGHAI JIAO TONG UNIVERSITY



1





2 hormesis

◆ 1943 Southam

hormone

hormesis

◆ hormesis

◆ " "

◆ " "

?





上海交通大学
SHANGHAI JIAO TONG UNIVERSITY





1

1

2

3

4

5

"

"





2

1

2

3

4





上海交通大学
SHANGHAI JIAO TONG UNIVERSITY

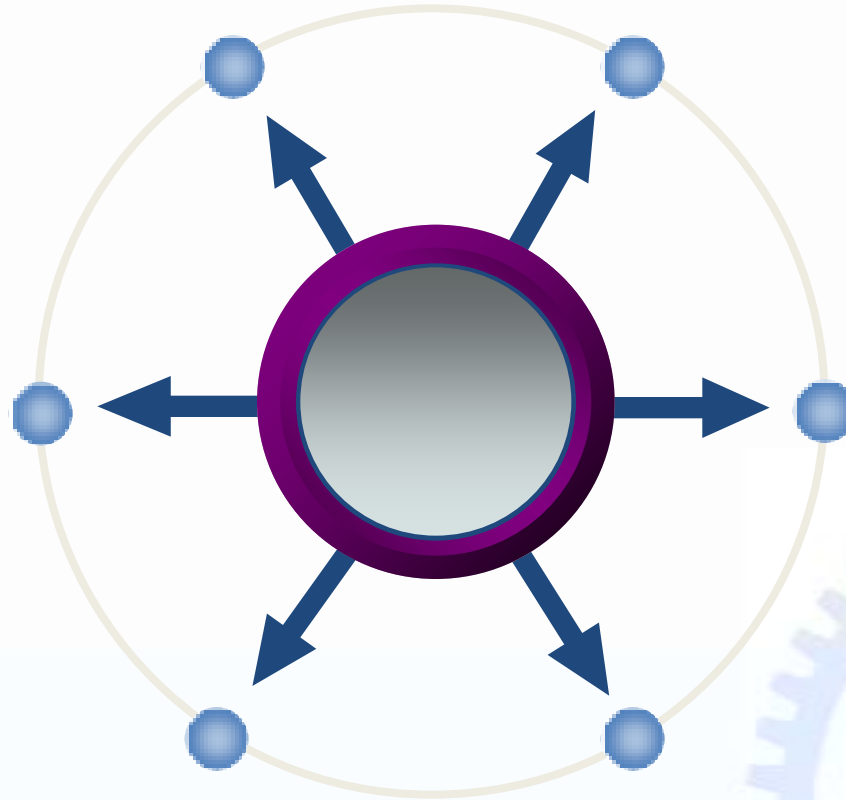



◆ SPE

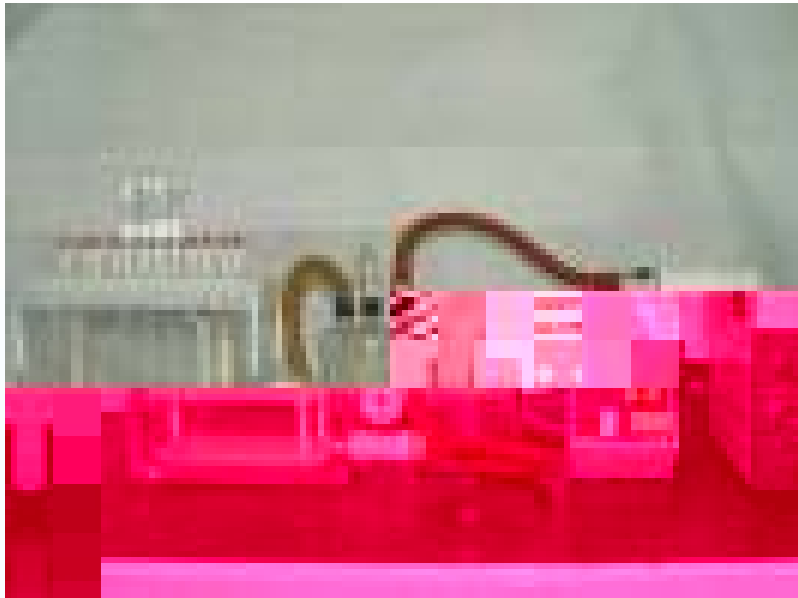



1.

2.

3.

4.

/

1/5

/

1/2

/





[a]

2012





SPME

(GC)

(HPLC)

SPME



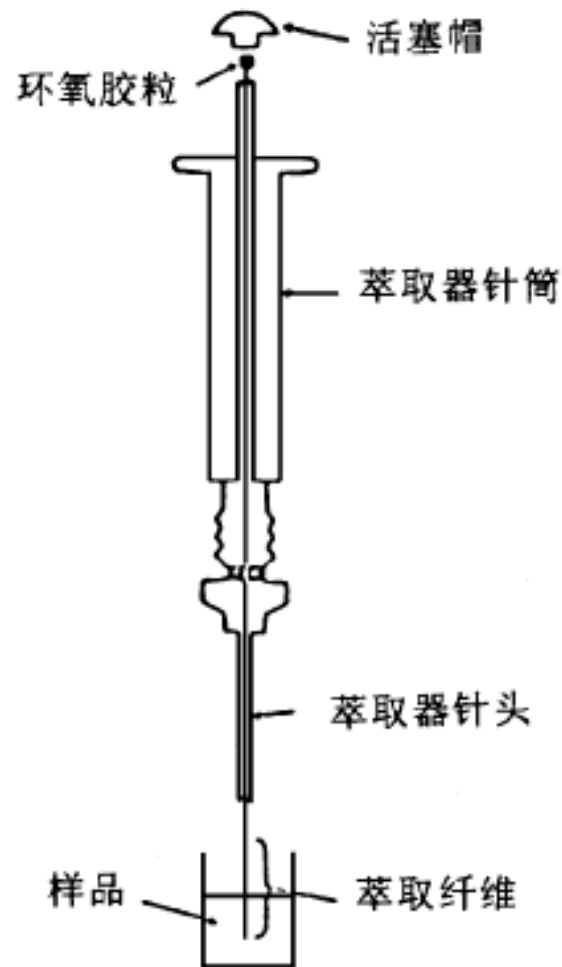
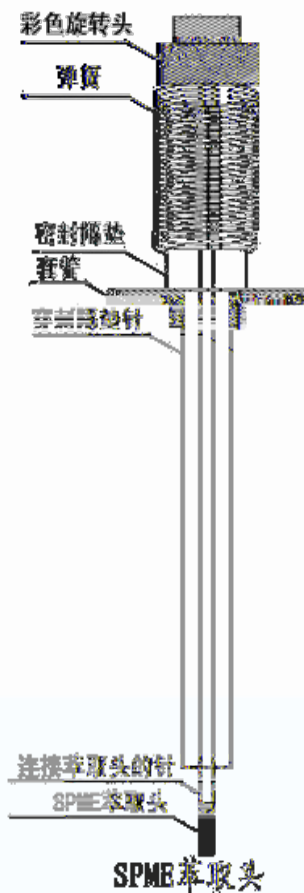
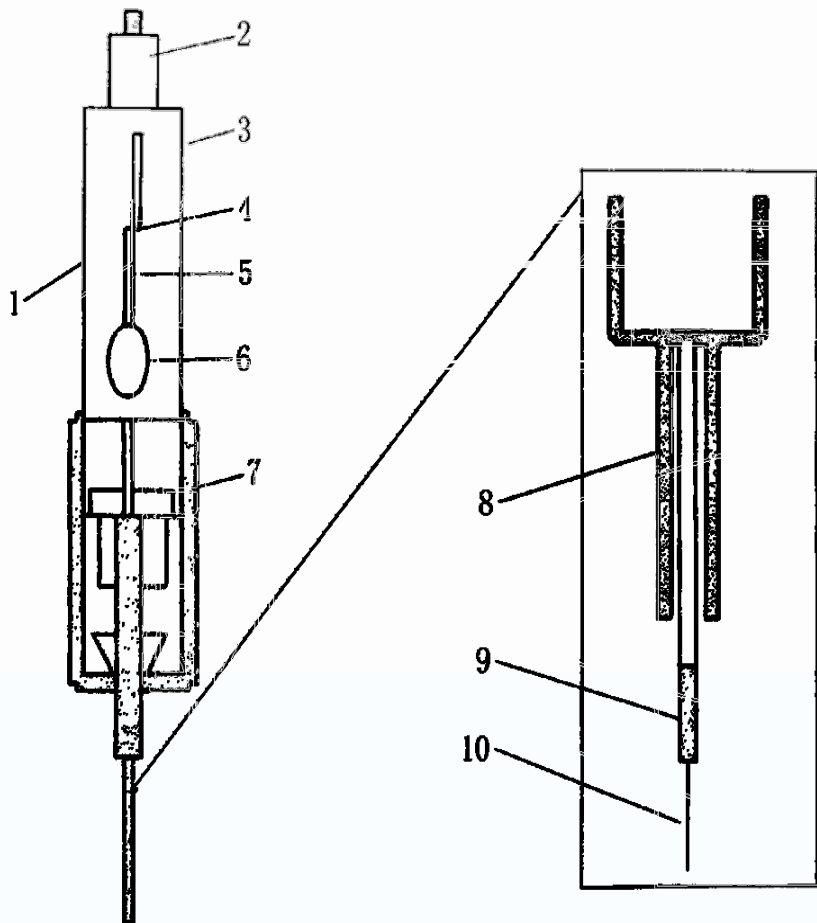

固相微萃取(SPME)萃取器



5000

6500

50

100

1200





(ASE)

(50-200)

(10.3-20.6MPa)

1g

1.5mL

15min

EPA





(SFE)

SFE

SFE





➔ (MSPD)

➔ (1 4)

MSPD





MSPD/HPLC - MS/MS

4 2-

C18

MCX

(MRM)

(2012



()





GP—MSE

(GC—MS)

(PCNB)

(PCA)

(PCTA)

2011

53

1896



methods, MRMs

20 80

Multi-residue





1

2

3





—

—



NS)

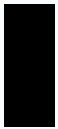



GC

HPLC

DI

MS

GC

—

GC-MS

HPLC

MS

—

LC-MS

MS

MS





/

-

(SPME/GC-MS)

,

,

2012

58

1896



1

2





3

4 X

X



60

1896



DNA





PCR





FRET





(Fluorescence Polarization Immunoassay FPIA)

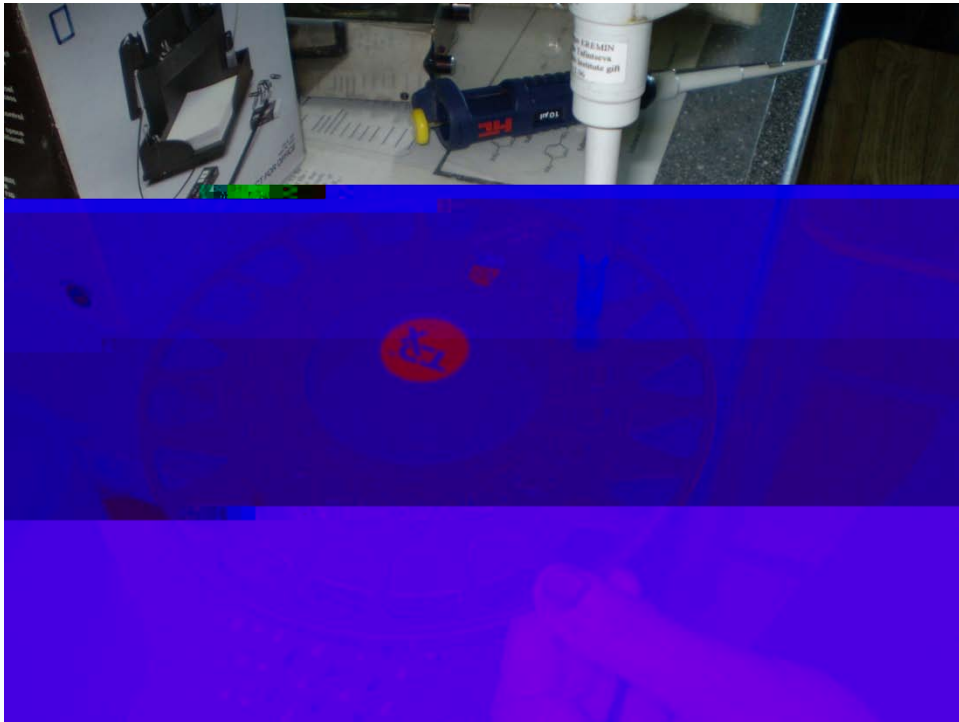

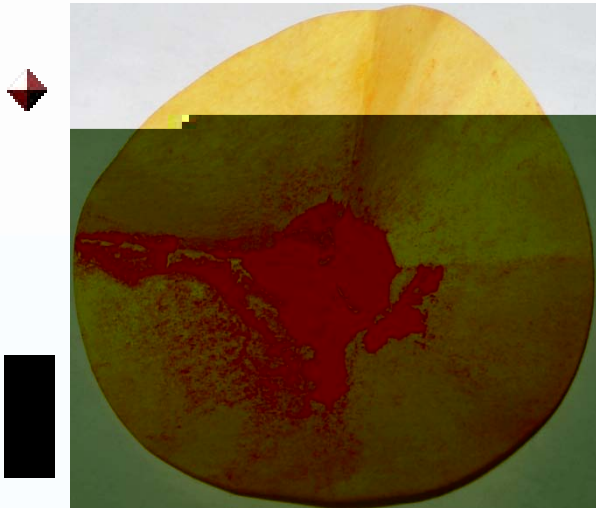

2010

65

1896



ELISA

ELISA





20

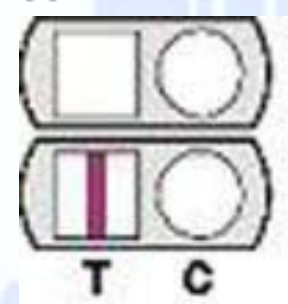
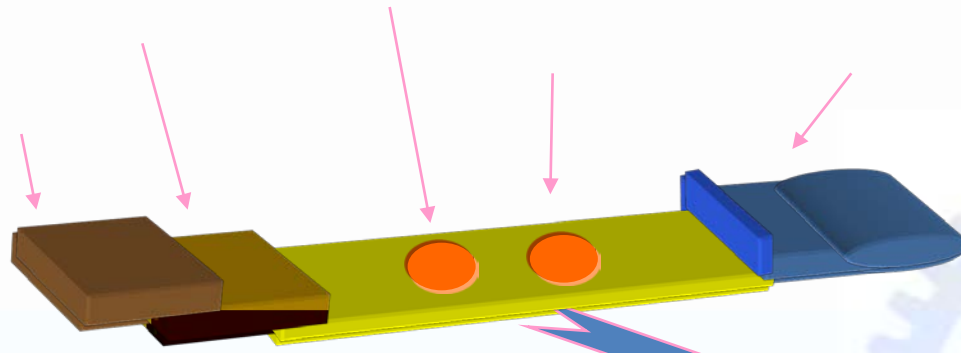

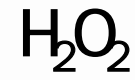

TMB

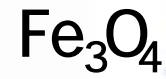



Fe_3O_4

Fe_3O_4

ELI SA



2011

69

1896



PCR

〈 PCR

DNA

〈 DNA

DNA RNA

〈 PCR

DNA

PCR

〈

PCR

PCR





上海交通大学
SHANGHAI JIAO TONG UNIVERSITY



<





<

DNA

DNA





(Aptamer) "

" (Systematic evolution of ligands by
exponential enrichment, SELEX

PCR





ATP





(RRS)

2012

75

1896



上海交通大学
SHANGHAI JIAO TONG UNIVERSITY



<





TFA)





上海交通大学
SHANGHAI JIAO TONG UNIVERSITY





上海交通大学
SHANGHAI JIAO TONG UNIVERSITY



Thanks for your attention

